

This article was downloaded by:

On: 26 January 2011

Access details: *Access Details: Free Access*

Publisher *Taylor & Francis*

Informa Ltd Registered in England and Wales Registered Number: 1072954 Registered office: Mortimer House, 37-41 Mortimer Street, London W1T 3JH, UK



Liquid Crystals

Publication details, including instructions for authors and subscription information:

<http://www.informaworld.com/smpp/title~content=t713926090>

Naphthyl benzoates versus phenyl benzoates A molecular structure-liquid crystal and ferroelectric behaviour relationship study

Yolanda González^a; M. Blanca Ros^a; Jose Luis Serrano^a; Miguel Angel Perez-jubindo^b

^a Química Orgánica, Facultad de Ciencias-I.C.M.A, Universidad de Zaragoza-C.S.I.C, Zaragoza, Spain ^b

Departamento de Física Aplicada II, Facultad de Ciencias, Universidad del País Vasco, Bilbao, Spain

To cite this Article González, Yolanda , Ros, M. Blanca , Serrano, Jose Luis and Perez-jubindo, Miguel Angel(1995) 'Naphthyl benzoates versus phenyl benzoates A molecular structure-liquid crystal and ferroelectric behaviour relationship study', *Liquid Crystals*, 18: 5, 751 – 760

To link to this Article: DOI: 10.1080/02678299508036686

URL: <http://dx.doi.org/10.1080/02678299508036686>

PLEASE SCROLL DOWN FOR ARTICLE

Full terms and conditions of use: <http://www.informaworld.com/terms-and-conditions-of-access.pdf>

This article may be used for research, teaching and private study purposes. Any substantial or systematic reproduction, re-distribution, re-selling, loan or sub-licensing, systematic supply or distribution in any form to anyone is expressly forbidden.

The publisher does not give any warranty express or implied or make any representation that the contents will be complete or accurate or up to date. The accuracy of any instructions, formulae and drug doses should be independently verified with primary sources. The publisher shall not be liable for any loss, actions, claims, proceedings, demand or costs or damages whatsoever or howsoever caused arising directly or indirectly in connection with or arising out of the use of this material.

Naphthyl benzoates versus phenyl benzoates

A molecular structure–liquid crystal and ferroelectric behaviour relationship study

by YOLANDA GONZÁLEZ†, M. BLANCA ROS†, JOSE LUIS SERRANO†*
and MIGUEL ANGEL PEREZ-JUBINDO‡

† Química Orgánica, Facultad de Ciencias-I.C.M.A,
Universidad de Zaragoza-C.S.I.C, 50009-Zaragoza, Spain

‡ Departamento de Física Aplicada II, Facultad de Ciencias,
Universidad del País Vasco, Aptdo. 644, 48080-Bilbao, Spain

(Received 9 February 1994; in final form 2 September 1994; accepted 1 October 1994)

A comparative study of the liquid crystal and ferroelectric properties of several achiral, racemic and non-racemic 2,6-naphthyl benzoates and their 1,4-phenyl benzoate analogues is reported. In terms of pure compounds, both central core structures give rise to similar mesophase sequences; however, the naphthalene derivatives exhibit broader and more thermally stable liquid crystalline states. On the other hand, both central core units give rise to equivalent electric and optoelectronic properties when the compounds are used as chiral dopants in ferroelectric liquid crystal mixtures.

1. Introduction

Since the discovery of liquid crystal behaviour [1], continuous efforts have been made to obtain the most suitable materials for use in technological applications [2,3]. As the field advances, the study of molecular structure–liquid crystal activity relationships has played a singularly important role. Based on this kind of study, properties such as mesophase type, transition point, sign of electrical susceptibility, or ferroelectric behaviour etc. can be controlled quite accurately.

From the chemical point of view, aromatic systems have proved to be the most useful structures to promote mesomorphic behaviour, and two or three aromatic ring systems are statistically the most common structures used to build the rigid central core [4].

Among these aromatic structures, interest in the naphthalene unit is increasing considerably and recent work on low [5–12] and high [13] molecular weight liquid crystal materials incorporating naphthalene have shown very attractive properties for some of these structures. High optical birefringence in the nematic phase [12], glassy states [7] or quasi-bookshelf ferroelectric liquid crystal order [8] have been described for low molecular weight naphthalene-based liquid crystals. Likewise, important high performance polymeric fibres such as VECTRA™, owe their interesting properties to the

‘crankshaft’ geometry provided by the 2,6-disubstituted naphthalene monomers [13].

From a structural point of view, the naphthalene system offers properties such as length and polarizability that positively influence the intermolecular interactions favouring mesophase formation. Evidence of these advantages are clear in that the compact, highly conjugated naphthyl moiety has been successfully used to promote the liquid crystal phases most suitable for display devices, i.e. nematic [11, 12] or chiral smectic C [8–10]. Furthermore, the naphthalene system offers numerous possibilities for disubstituted derivatives [14, 15] that make it a very versatile core unit.

In the course of our research, we have synthesized a wide variety of naphthyl compounds, along with some of their phenyl analogues, which have enabled us to assess the similarities and differences between the two aromatic systems, a comparison not widely reported in the literature [16, 17].

In order to evaluate the a priori practical advantages of incorporating the two-ring naphthalene system in the structures of liquid crystalline materials, we report in this paper a comparative study of the mesomorphic properties of the 2,6-naphthyl benzoate central core and those of its closely related two-ring analogue, the well-known phenyl benzoate core, which we will consider as the parent model structure.

With this purpose in mind, our study has been focused

* Author for correspondence.

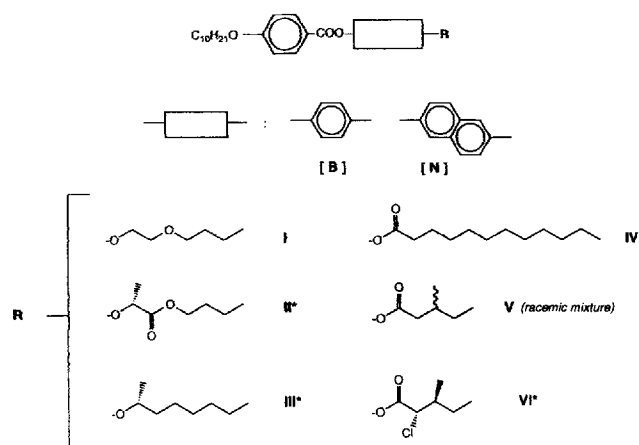

Figure 1.

on two series of naphthyl [N] and phenyl [B] benzoates with different ether or ester terminal chains (both achiral and chiral) (see figure 1).

A number of the compounds prepared are enantiomerically pure, so they are of particular interest as ferroelectric liquid crystals, either as pure compounds if they exhibit the potentially ferroelectric chiral smectic C phase (S_C^*), or alternatively as chiral guests for induced ferroelectric liquid crystal blends. In this context, all of the non-racemic compounds have been studied as 10 mol% binary mixtures with the commonly used achiral host 4-hexyloxyphenyl 4-decyloxybenzoate [C 62.5°C S_C 78.2°C S_A 84.5°C N 90.5°C I].

The terminal chains considered are significantly different in terms of length, dipole moments and linearity, in order to allow representative conclusions to be drawn. Furthermore, the different tail groups are substituted directly onto the central naphthyl or phenyl core unit which will more strongly influence the mesomorphic/ferroelectric properties.

2. Results and discussion

2.1. Mesophase characterization

The compounds and mixtures studied exhibit typical textures [18] which allowed their identification by polarizing optical microscopy. The nematic, smectic A and smectic C phases were identified, on cooling, by their schlieren, homeotropic/focal-conic and schlieren/broken fan textures, respectively. In the case of the chiral phases, the cholesteric phase was identified by the Grandjean plane, polygonal and oily streak textures, whereas in the chiral smectic C phases, mainly pseudo-homeotropic and focal-conic textures were observed.

Most of the binary mixtures prepared exhibit and ordered orthogonal smectic phase below the S_C^* phase. This mesophase has been tentatively characterized as a hexatic S_B phase on the basis of a striped fan-shaped

texture coexisting with homeotropic regions. The nature of the monotropic orthogonal phase could not be confirmed by X-ray diffraction due to crystallization of the material shortly after the transition occurred on cooling. This orthogonal phase has also been detected by other authors [19] and occasionally by ourselves in the achiral host, although simultaneous crystallization often occurs at the transition.

2.2. Liquid crystal properties

The phase sequences and transition temperatures for the samples studied were determined by thermal polarized light microscopy and differential scanning calorimetry. The results for the pure compounds are given in table 1

Table 1. Phase transitions of pure compounds.

Compound	Phase transition temperature/°C \ddagger
B-I	C 53.5 S_C -N 55.0 I I 54.7 N 53.2 S_C 38.1 C
N-I	C 63.0 S_C 72.3 N 98.3 I
B-II*	C 13.2 I I -10.4 Ch -23.6 C
N-II*	C 54.3 I I 30.0 Ch 16.4 C
B-III*§	C 37.9 I I 24.2 S_A 8.7 C
N-III*	C 68.7 I I 59.2 Ch 55.3 S_A 48.0 S_C^* 31.5 C
B-IV	C 65.8 S_C 92.4 N 94.4 I
N-IV	C ₁ 60.0 C ₂ 66.7 C ₃ 72.5 S_C 121.8 N 131.7 I
B-V	C 45.3 S_C 59.7 S_A 62.9 N 73.0 I
N-V	C 64.8 S_C 87.9 N 122.3 I
B-VI*¶	C 66.5 I I 51.0 S_A 37.0 S_C^* 28.0 C
N-VI*	C 68.1 S_C^* 75.0¶ S_A 95.0 Ch 99.5 I

\ddagger Data refer to the second DSC cycle.

\ddagger I = Isotropic liquid, N = Nematic phase, Ch = Cholesteric phase, S_A = Smectic A phase, S_C = Smectic C phase, S_C^* = Chiral smectic C phase, C = Crystal phase.

§ (S)-Enantiomer first reported in [23].

|| Optical microscopic data.

¶¶ Compound first reported in [34], but FLC properties not published.

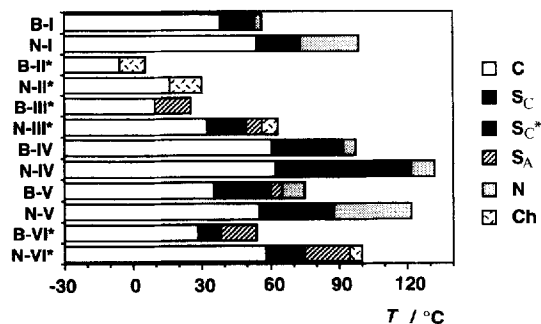

Figure 2. Mesophase ranges on cooling the pure compounds.

and the cooling processes are represented graphically in figure 2.

It can be seen that all of the compounds prepared are mesomorphic. Their melting points are below 70°C and, in some cases (**B-II***, **N-II***, **B-III***, **N-III*** and **B-VI***) the mesophase appears below or at room temperature.

In general, for the compounds incorporating the same terminal chain, both naphthyl and phenyl derivatives show similar phase sequences. However, it can be seen that the naphthalene compounds give rise to higher melting points, more stable mesophases and wider liquid crystalline phase ranges (in the order of 30°C higher) in comparison with their phenyl analogues. The naphthyl unit in particular is efficient in generating smectic C phases. The S_C mesophase ranges in the naphthyl derivatives are broader than those in the phenyl analogues. These results are in contrast to those reported by Goodby for pairs of naphthalene/benzene derivatives [17].

These properties are a direct consequence of the molecular arrangement in both the solid and the liquid crystal phases. As mentioned previously, the phenyl and naphthyl central core units differ mainly in their length and extension of the electronic conjugation. The increased transition temperatures can clearly be attributed to the increased length (a difference of around 2.5 Å using Dreiding models) and higher polarizability of the naphthalene structures that allow both stronger and a wider ranging of molecular interactions.

As far as the terminal tails are concerned some trends can be highlighted which are in good agreement with results reported in the literature. Firstly, there is the strong influence of the ester chains in promoting smectic order, even when short chain lengths and ramifications (chain branchings) are involved.

All of the ether derivatives have a similar chain length however, depending on electronic and steric factors, their properties show important differences. Thus, if we compare the liquid crystal behaviour of compounds **B-I**, **B-II*** and **B-III*** with those of the linear alkoxy analogue, 4-octyloxyphenyl 4-decyloxybenzoate [C 70.5°C S_C 85.5°C S_A 87.4°C N 91.5°C I] [20], we can see that the replacement of a methylene group by an oxygen (**B-I**) results in a destabilization of the mesophases and a lowering of the phase transition temperatures. These results have been attributed to the fact that the chain flexibility increases and the polarizability for the alkoxy-alkoxy chain diminishes [21].

On the other hand, the negative effect that ramifications close to the central core have on mesophase formation can be clearly seen in the rest of the derivatives with ether tails (**II*** and **III***). For both types of structure, the methyl group hinders the central core interactions giving rise to monotropic liquid crystal order. The phase type is less stable and/or ordered for the shorter phenyl derivatives.

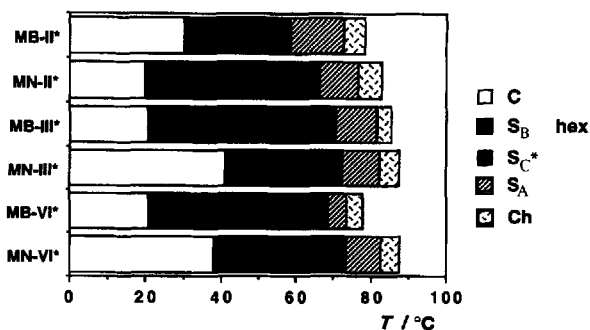

Figure 3. Mesophase ranges on cooling the 10 mol % chiral binary mixtures of the non-racemic compounds with 4-hexyloxyphenyl 4-decyloxybenzoate.

2.3. Ferroelectric behaviour

In order to assess and compare the FLC properties for both central cores, we evaluated the ferroelectric properties of the pure compounds, as well as those of their 10 mol % binary mixtures in the achiral host previously mentioned (see figure 3). The most representative properties of these blends are summarized in table 2.

If we first consider the pure compounds and, in particular the compounds **B-VI***/**N-VI***, we can see that 10°C below the S_A - S_C^* transition, both compounds show similar electro-optical response times (τE), although the spontaneous polarization (P_s) and rotational viscosity (γ_c) of the naphthalene derivative are half those of the corresponding phenyl derivative. Likewise, as a consequence of the larger S_C^* phase range for **N-VI***, the P_s value rises to a maximum of 135 nC cm⁻² compared with 99 nC cm⁻² for the phenyl compound **B-VI***.

The limited data available do not therefore allow conclusions to be drawn about the influence of both central cores studied on the FLC behaviour.

In the case of the binary mixtures, it can be seen from the data in table 2 and figure 4, that the most significant differences observed arise from the nature of the chiral tail, rather than from the central cores. The high proportion of the achiral host in the mixtures greatly diminishes the influence of the different central cores on the dipolar molecular coupling.

Regardless of the nature of the central core unit, the binary mixtures, when cooled by 10 degrees into the ferroelectric phase, have almost identical values of rotational viscosity, response time, spontaneous polarization and tilt angle, and therefore normalized spontaneous polarization (P_o) for a given chiral chain (see table 2).

A similar trend can be observed if we compare the values of these parameters over an extended temperature range for all the mixtures P_s (see figure 4(a)), tilt angles (see figure 4(b)) and switching times (see figure 4(c)). In each case the mixtures show parameters with very similar magnitudes. The only significant differences are

Table 2. Ferroelectric properties of the pure chiral compounds and their binary mixtures (denoted by M).

Sample	S_C^* Range/ $^{\circ}\text{C}$	P_{Smax} (nC cm $^{-2}$)	P_s /nC cm $^{-2}$	τE_{\ddagger}^{\S} /μsV μm $^{-1}$	γc_{\ddagger} /Pa s	Θ_{\ddagger} / $^{\circ}$	P_o_{\ddagger} /nC cm $^{-2}$
N-III*	13	+33	31	1240	0.223	20	91
B-VI*	10	-99	99	495	0.280		
N-VI*	35	-135	54	437	0.136	18	175
MB-II*¶	23	+7.0	4.8	260	0.007	20	14
MN-II*¶	29	+8.5	5.1	258	0.008	22	14
MB-III*¶	30	+3.2	2.3	188	0.003	16	8
MN-III*¶	30	+2.0	2.0	267	0.003	18	7
MB-VI*¶	31	-6.8	6.2	200	0.007	18	20
MN-VI*¶	35	-10.0	6.9	190	0.007	18	22

† On cooling the sample from the isotropic liquid.

‡ Data measured at $T_c - T = 10^{\circ}\text{C}$ (T_c : $S_A - S_C^*$ phase transition temperature).

§ Data measured applying 4 volts per micron.

|| The poor alignment of the sample prevented an accurate measurement.

¶ 10 mol % binary mixture using 4-hexyloxyphenyl 4-decyloxybenzoate as achiral host.

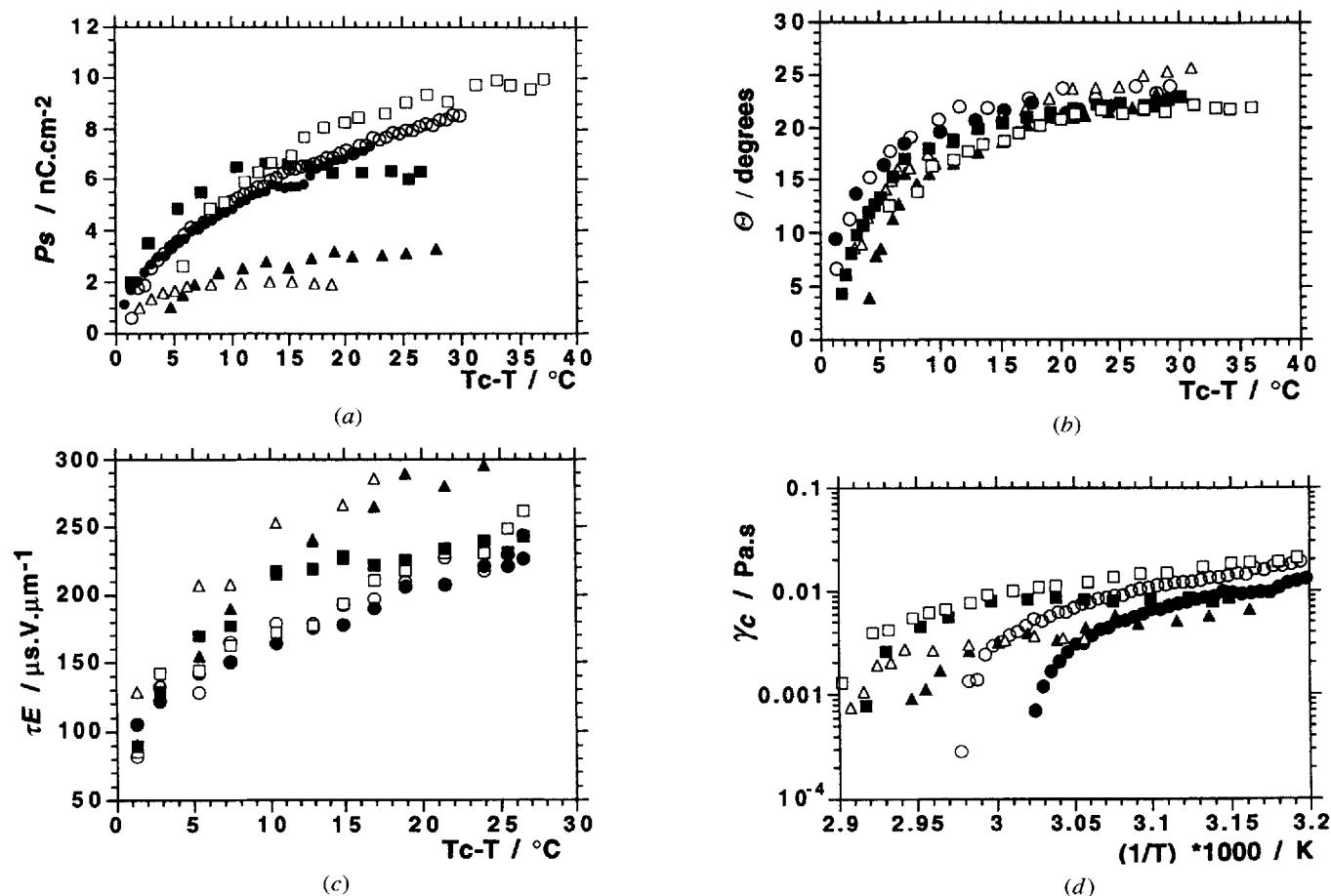

Figure 4. Temperature dependence of the physical properties of the binary mixtures: (a) spontaneous polarization; (b) tilt angles; (c) switching times and (d) rotational viscosities. [●] B-II*; [○] N-II*; [▲] B-III*; [△] N-III*; [■] B-VI*; [□] N-VI*.

observed in the case of the chloroester derivatives, where differences in P_s of 2 nC cm^{-2} separate the naphthyl from the phenyl mixture near the saturation values.

As far as the sign of P_s is concerned, no changes of direction were observed throughout the S_C^* range, and the sign depends only on the nature of the chiral tail. In this sense, the alkyl acetate tail is also responsible for the most tilted molecular arrangement in the ferroelectric phase.

The best ferroelectric properties are obtained for the α -chloroester and alkyl lactate tails, as would be expected given the dipole moments associated with them. MM2-AM1 conformational calculations for the tails (*R*)-II* and (*R*)-III* [22] showed that the most abundant conformations are very similar and comparable. Furthermore, the 'extra' dipole moment associated with the ester bond of the chain in II* is partially added to the dipole moment due to the lone electron pairs of the ether oxygen atom, which are mainly responsible for the polar contribution derived from the 1-methylheptyloxy tail [23]. This fact can satisfactorily explain both the positive sign, as well as the substantially higher magnitude of the spontaneous polarization for the alkyl lactate derivatives.

More difficult comparisons can be made with the chloro-ester compounds. Nevertheless, on the basis of our previous results [9], the strong dipole moment of the C–Cl bond, along with decisive steric factors inherent in this tail justify the high ferroelectric values obtained for these derivatives.

Well below the S_A – S_C^* transition, the rotational viscosity η ($\gamma_c = \eta/\sin^2 \theta$) [24] exhibits an Arrhenius-type dependence in the range of 0.004–0.03 Pa s. However, the slopes of the graphs are nearly the same for both central core units for a given tail. This signifies that independent of the nature of chiral tail, the activation energy in the switching process between the two states [25] is similar in these mixtures.

On the other hand, the chiral tail clearly influences the viscosity of the material and the lowest values were measured for the 1-methylheptyloxy derivatives. Some authors have attributed observations of this kind to the different dipole moments associated with the tails [26].

It is well known that the presence of helix unwinding lines in S_C^* textures is related to the magnitude of the pitch of the helix which is characteristic of this mesophase [27]. These pitch bands are easily detected by routine optical microscopy if they are of the order of a few μm [28]. Of all the S_C^* materials studied here, these pitch bands were observed only for N-III* and its mixture MN-III*, so no firm conclusions can be drawn regarding to this point.

One of the attractions of the naphthalene ring in the FLC field is claimed to be that it offers the possibility of obtaining a quasi-bookshelf arrangement in the S_C^* phase, which avoids undesirable chevrons [8]. Unfortunately, in our studies of both pure compounds and mixtures of

compounds containing the naphthalene unit, chevrons were detected in samples with a planar alignment regardless of the cell thickness.

3. Conclusions

The liquid crystal and ferroelectric properties of a group of achiral, racemic and non-racemic naphthyl and phenyl benzoate analogues have been studied and compared.

In terms of the pure compounds, the naphthalene derivatives are the more interesting. They show broad range and stable mesophases, S_C phase in particular, making them attractive candidates as S_C hosts in mixtures. In contrast, as chiral dopants in ferroelectric mixtures, both the phenyl and naphthyl central core units induce very similar electric and opto-electric properties. In addition, the low melting points of the phenyl benzoate derivatives make them potentially useful for lowering transition temperatures in mixtures.

4. Experimental

4.1. Synthesis

The compounds studied were prepared according to the synthetic pathway shown in the scheme.

Their synthesis involved the preparation of a monohydroxy-decyloxy derivative (**4** or **6**) that was subsequently either etherified (by Mitsunobu reaction) or esterified (via the acid chloride) to obtain the target compounds.

In the case of the naphthalene derivatives, the 6-hydroxynaphth-2-yl 4-decyloxybenzoate (**4**) was synthesized following a literature synthetic method [9].

For the phenyl benzoate derivatives, similar reactions were carried out on the 4-hydroxyphenyl 4-decyloxybenzoate (**6**) prepared by a two step synthesis from commercial 4-benzyloxyphenol. The α -chloroacid, derived from L-Isoleucine, was synthesized according to a method described elsewhere [9]. The precursors required for the rest of the terminal chains used in this study were commercially available.

4.1.1. Preparation 4-benzyloxyphenyl 4-decyloxybenzoate (**5**)

To an argon-flushed flask containing a suspension of sodium hydride (0.53 g, 22 mmol) in dry tetrahydrofuran (80 ml), 4-benzyloxyphenol (4.39 g, 22 mmol) was added slowly and the mixture stirred for 10 min. Then 4-decyloxybenzoyl chloride (6.85 g, 22 mmol) was added via a syringe and the resultant reaction mixture stirred at room temperature for 24 h. Water (40 ml) was added carefully and the slurry obtained was shaken with ethyl ether (60 ml). The organic phase was washed with 2 M HCl (2×40 ml), 5 per cent NaOH (2×40 ml), brine and dried (MgSO_4). The solvent was removed and the product was recrystallized (ethanol). (Yield 91 per cent). m.p. 96.3°C .

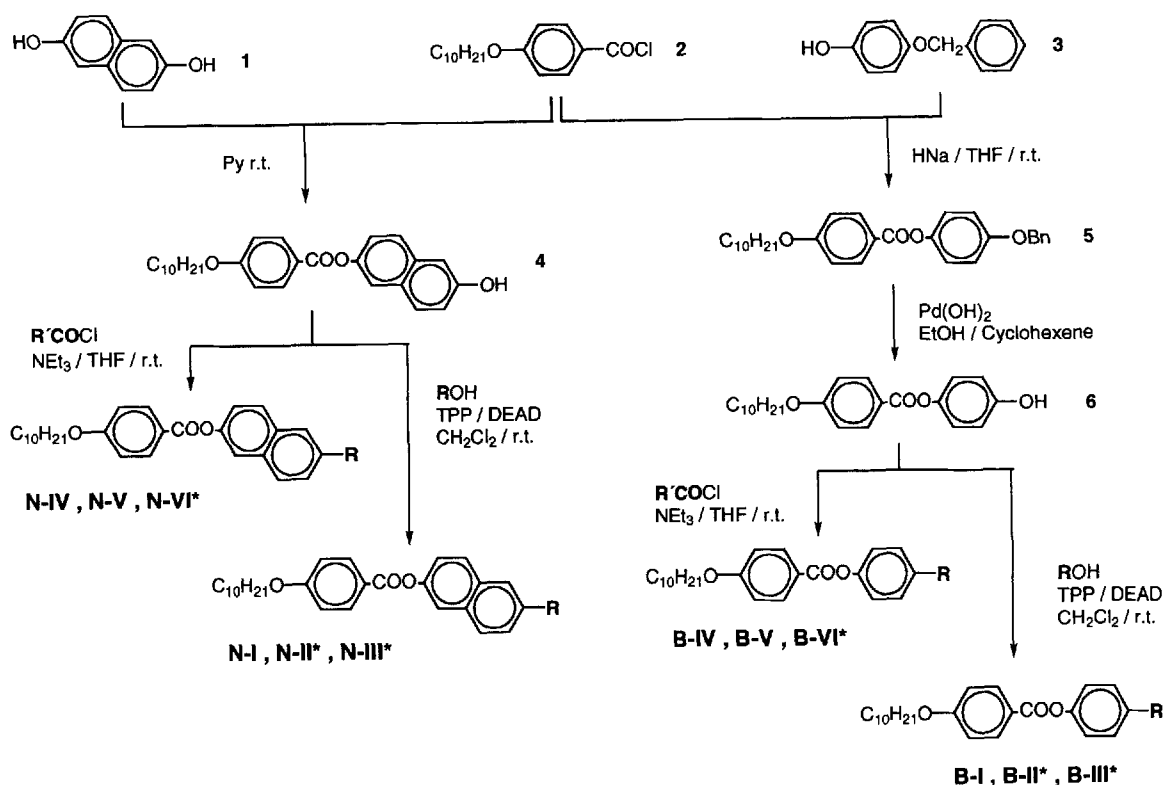

Scheme.

^1H NMR (300 MHz, CDCl_3): δ 0.86 (t, $J = 6.6$ Hz, 3 H), 1.26–1.51 (m, 14 H), 1.8 (m, 2 H), 3.88 (t, $J = 6.6$ Hz, 2 H), 5.07 (s, 2 H), 6.94 (d, $J = 8.7$ Hz, 2 H), 6.98 (d, $J = 9.0$ Hz, 2 H), 7.1 (d, $J = 9.0$ Hz, 2 H), 7.35–7.44 (m, 5 H), 8.1 (d, $J = 8.7$ Hz, 2 H). IR (nujol): 1722, 1607, 1501, 1292, 1089 cm^{-1} .

4.1.2. Preparation of 4-hydroxyphenyl 4-decyloxybenzoate (**6**)

An argon-flushed flask containing a suspension of compound **5** (3.64 g, 7.9 mmol), ethanol (63 ml), cyclohexene (40 ml) and $\text{Pd}(\text{OH})_2$ on charcoal catalyst (500 mg) was heated under reflux with continuous stirring for 4 h (monitoring by thin layer chromatography determined the end of the reaction). The mixture was allowed to cool and then filtered through a pad of celite, eluting several times with ethyl acetate. The solvent was removed and the product recrystallized from ethanol. (Yield 95 per cent). m.p. 107.2°C. ^1H NMR (300 MHz, CDCl_3): δ 0.86 (t, $J = 6.6$ Hz, 3 H), 1.22–1.51 (m, 14 H), 1.80 (m, 2 H), 4.02 (t, $J = 6.6$ Hz, 2 H), 5.26 (s, 1 H), 6.80 (d, $J = 8.8$ Hz, 2 H), 6.95 (d, $J = 8.9$ Hz, 2 H), 7.04 (d, $J = 8.9$ Hz, 2 H), 8.13 (d, $J = 8.8$ Hz, 2 H). IR (Nujol): 3462, 1713, 1607, 1510, 1287, 7185, 1089 cm^{-1} .

4.1.3. Representative procedure for obtaining the ether derivatives

A solution of the corresponding alcohol (1.8 mmol) in dry dichloromethane (5 ml) was added via a syringe to an argon flushed flask containing a solution of phenol (**4** or **6**) (1.8 mmol) and triphenyl phosphine (TPP) (2.2 mmol) in dry dichloromethane (20 ml). A solution of diethyl azodicarboxylate (DEAD) (2.13 mmol) in dry dichloromethane (20 ml) was added dropwise. The reaction mixture was stirred at room temperature for 23 h. Five drops of water were added and the reaction mixture was stirred for another 1 h. The solvent was removed by evaporation and the residual solid suspended in a mixture of hexane/ethyl acetate (7:3) and stirred for 1 h. The white solid was filtered off through a silica gel pad. The solvent was removed and the product was purified by flash chromatography on silica gel, eluting with hexane/dichloromethane mixtures. The products were recrystallized twice from absolute ethanol.

4.1.4. 4-(2-Butoxyethoxy)phenyl 4-decyloxybenzoate (**B-I**)

R_f 0.08 (50:50 hexane:dichloromethane). ^1H NMR (300 MHz, CDCl_3): δ 0.84–0.93 (m, 6 H), 1.26–1.45 (m,

16H), 1.55–1.61 (m, 2H), 1.77–1.82 (m, 2H), 3.52 (t, $J = 6.6$ Hz, 2H), 3.77 (t, $J = 4.8$ Hz, 2H), 4.01 (t, $J = 6.6$ Hz, 2H), 4.1 (t, $J = 4.8$ Hz, 2H), 6.91–6.95 (m, 4H), 7.08 (d, $J = 9.0$ Hz, 2H), 8.1 (d, $J = 9.0$ Hz, 2H). IR (Nujol): 1721, 1608, 1514, 1262, 1203, 1078 cm^{-1} . Elemental analysis: calculated for $\text{C}_{29}\text{H}_{42}\text{O}_5$: C, 73.99; H, 9.01. Found: C, 74.08; H, 8.92 per cent.

4.1.5. 6-(2-Butoxyethoxy)naphth-2-yl
4-decyloxybenzoate (**N-I**)

R_f : 0.13 (50:50 hexane:dichloromethane). ^1H NMR (300 MHz, CDCl_3): δ 0.84–0.94 (m, 16H), 1.22–1.50 (m, 2H), 1.56–1.65 (m, 2H), 1.76–1.85 (m, 2H), 3.55 (t, $J = 6.6$ Hz, 2H), 3.84 (t, $J = 4.9$ Hz, 2H), 4.03 (t, $J = 6.6$ Hz, 2H), 4.22 (t, $J = 4.9$ Hz, 2H), 6.96 (d, $J = 9.0$ Hz, 2H), 7.17 (dd, $J = 9.0$ Hz, $J = 2.4$ Hz, 1H), 7.21 (dd, $J = 2.4$ Hz, 1H), 7.28 (dd, $J = 9.0$ Hz, $J = 2.4$ Hz, 1H), 7.57 (d, $J = 2.2$ Hz, 1H), 7.69 (d, $J = 9.0$ Hz, 1H), 7.74 (d, $J = 9.0$ Hz, 1H), 8.16 (d, $J = 9.0$ Hz, 2H). IR (Nujol): 1728, 1600, 1509, 1289, 1254 cm^{-1} . Elemental analysis: calculated for $\text{C}_{33}\text{H}_{44}\text{O}_5$: C, 76.10; H, 8.53. Found: C, 76.33; H, 9.05 per cent.

4.1.6. (R)-4-(2-Butoxycarbonylethoxy)phenyl
4-decyloxybenzoate (**B-II***)

R_f : 0.13 (50:50 hexane:dichloromethane). ^1H NMR (300 MHz, CDCl_3): δ 0.84–0.91 (m, 6H), 1.23–1.45 (m, 16H), 1.54–1.62 (m, 2H), (d, $J = 6.77$ Hz, 3H), 1.77–1.82 (m, 2H), 4.01 (t, $J = 6.6$ Hz, 2H), 4.15 (t, $J = 6.6$ Hz, 2H), 4.71 (q, $J = 6.8$ Hz, 1H), 6.88 (q, $J = 9.0$ Hz, 2H), 6.93 (d, $J = 9.0$ Hz, 2H), 7.07 (d, $J = 9.2$ Hz, 2H), 8.0 (d, $J = 9.0$ Hz, 2H). IR (Nujol): 1753, 1734, 1606, 1510, 1256, 1195, 1166 cm^{-1} .

4.1.7. (R)-6-(2-Butoxycarbonylethoxy)naphth-2-yl
4-decyloxybenzoate (**N-II***)

R_f : 0.15 (50:50 hexane:dichloromethane). ^1H NMR (300 MHz, CDCl_3): δ 0.81–0.89 (m, 6H), 1.23–1.58 (m, 16H), 1.60–1.68 (m, 2H), 1.79 (d, $J = 6.4$ Hz, 3H), 1.80–1.83 (m, 2H), 4.03 (t, $J = 6.6$ Hz, 2H), 4.16 (t, $J = 6.6$ Hz, 2H), 4.89 (q, $J = 7$ Hz, 1H), 6.97 (d, $J = 9.0$ Hz, 2H), 7.06 (d, $J = 2.4$ Hz, 1H), 7.2 (dd, $J = 9.0$ Hz, $J = 2.6$ Hz, 1H), 7.28 (dd, $J = 9.0$ Hz, $J = 2.6$ Hz, 1H), 7.58 (d, $J = 2.2$ Hz, 1H), 7.71 (d, $J = 8.8$ Hz, 1H), 7.72 (d, $J = 8.98$ Hz, 1H), 8.16 (d, $J = 9.0$ Hz, 2H). IR (Nujol): 1735, 1606, 1509, 1252, 1196, 1165 cm^{-1} . Elemental analysis: calculated for $\text{C}_{33}\text{H}_{44}\text{O}_6$: C, 72.22; H, 8.10. Found: C, 72.51; H, 8.12 per cent.

4.1.8. (R)-4-(1-Methylheptyloxy)phenyl 4-decyloxy
benzoate (**B-III***)

R_f : 0.81 (50:50 hexane:dichloromethane). ^1H NMR (300 MHz, CDCl_3): δ 0.86 (t, 6H), 1.20–1.55 (m, 22H), 1.32 (d, 3H), 1.65 (m, 1H), 1.79 (m, 3H), 4.02

(t, $J = 6.6$ Hz, 2H), 4.30 (m, $J = 6$ Hz, 1H), 6.88 (d, $J = 9.3$ Hz, 1H), 6.93 (d, $J = 9.0$ Hz, 2H), 7.07 (d, $J = 9.3$ Hz, 2H), 8.11 (d, $J = 9.0$ Hz, 2H). IR (Nujol): 1726, 1607, 1510, 1275, 1200, 1078 cm^{-1} . Elemental analysis calculated for $\text{C}_{31}\text{H}_{46}\text{O}_4$: C, 77.10; H, 9.60. Found C, 77.40; H, 9.80 per cent.

4.1.9. (R)-6-(1-Methylheptyloxy)naphth-2-yl
4-decyloxybenzoate (**N-III***)

R_f : 0.52 (50:50 hexane:dichloromethane). ^1H NMR (300 MHz, CDCl_3): δ 0.86–0.89 (m, 6H), 1.20–1.60 (m, 22H), 1.37 (d, $J = 6.1$ Hz, 3H), 1.60 (m, 1H), 1.80–1.90 (m, 3H), 4.05 (t, $J = 6.6$ Hz, 2H), 4.5 (m, 1H), 6.98 (d, $J = 9.0$ Hz, 2H), 7.13–7.18 (m, 2H), 7.29 (dd, $J = 8.8$ Hz, $J = 2.2$ Hz, 1H), 7.58 (d, $J = 2.2$ Hz, 1H), 7.73 (d, $J = 8.8$ Hz, 1H), 7.74 (d, $J = 8.8$ Hz, 1H), 8.18 (d, $J = 8.8$ Hz, 2H). IR (Nujol): 1729, 1606, 1512, 1274, 1222, 1177 cm^{-1} . Elemental analysis calculated for $\text{C}_{35}\text{H}_{48}\text{O}_4$: C, 78.89; H, 9.10. Found C, 79.16; H, 9.36 per cent.

4.1.10. Representative procedure for obtaining the ester
compounds

To an argon-flushed flask containing a stirred solution of the phenol (**4** or **6**) (1.62 mmol) in dry tetrahydrofuran (7 ml) and freshly distilled triethylamine (1.98 mmol), a solution of the corresponding acid chloride in dry tetrahydrofuran (3 ml) was added dropwise via a syringe. After stirring for 16 h at room temperature, the solvent was removed and the product purified by flash chromatography on silica gel, eluting with hexane/dichloromethane mixtures. The pure product was recrystallized twice from absolute ethanol.

4.1.11. 4-(4-Decyloxybenzoyloxy)phenyl dodecanoate
(**B-IV**)

R_f : 0.40 (50:50 hexane:dichloromethane). ^1H NMR (300 MHz, CDCl_3): δ 0.86 (t, 6H), 1.25–1.36 (m, 30H), 1.71–1.82 (m, 4H), 2.54 (t, $J = 6.6$ Hz, 2H), 4.03 (t, $J = 6.6$ Hz, 2H), 6.94 (d, $J = 8.8$ Hz, 2H); 7.1 (d, $J = 8.8$ Hz, 2H), 7.19 (d, $J = 8.9$ Hz, 2H), 8.1 (d, $J = 8.8$ Hz, 2H). IR (Nujol): 1754, 1722, 1609, 1510, 1295, 1256, 1243 cm^{-1} . Elemental analysis: calculated for $\text{C}_{35}\text{H}_{45}\text{O}_5$: C, 76.03; H, 9.50. Found: C, 76.38; H, 9.82 per cent.

4.1.12. 6-(4-Decyloxybenzoyloxy)naphth-2-yl
dodecanoate (**N-IV**)

R_f : 0.36 (50:50 hexane:dichloromethane). ^1H NMR (300 MHz, CDCl_3): δ 0.86 (t, $J = 6.6$ Hz, 3H), 1.22–1.47 (m, 30H), 1.72–1.83 (m, 4H), 2.59 (t, $J = 6.6$ Hz, 2H), 4.03 (t, $J = 6.6$ Hz, 2H), 6.82 (d, $J = 9.0$ Hz, 2H), 7.22 (dd, $J = 9.0$ Hz, $J = 2.2$ Hz, 1H), 7.34 (dd, $J = 9.0$ Hz, $J = 2.2$ Hz, 1H), 7.56 (d, $J = 2.2$ Hz, 1H), 7.66

(d, $J = 2.2$ Hz, 1 H), 7.79–7.83 (d, $J = 9.0$ Hz, 2 H), 8.17 (d, $J = 9.0$ Hz, 2 H). IR (Nujol): 1762, 1724, 1605, 1511, 1281, 1258 cm^{-1} . Elemental analysis: calculated for $\text{C}_{39}\text{H}_{54}\text{O}_5$: C, 77.69; H, 9.05. Found: C, 77.82; H, 9.60 per cent.

4.1.13. *4-d-Decyloxybenzoyloxyphenyl 3-methylpentanoate (B-V)*

R_f 0.29 (50:50 hexane:dichloromethane). ^1H NMR (300 MHz, CDCl_3): δ 0.86 (t, $J = 6.6$ Hz, 3 H), 0.94 (t, $J = 7.5$ Hz, 3 H), 1.03 (d, $J = 6.6$ Hz, 3 H), 1.23–1.48 (m, 16 H), 1.77–1.82 (m, 2 H), 2.0–2.03 (m, 1 H), 2.34 (dd, $J = 8.0$ Hz, 1 H), 2.55 (dd, $J = 6.0$ Hz, 1 H), 4.02 (t, $J = 6.6$ Hz, 2 H), 6.95 (d, 9.0 Hz, 2 H), 7.1 (d, $J = 8.8$ Hz, 1 H), 7.19 (d, $J = 9.0$ Hz, 2 H), 8.11 (8.8 2 H). IR (Nujol): 1754, 1725, 1608, 1512, 1278, 1262, 1184, 1171, 1077 cm^{-1} . Elemental analysis: calculated for $\text{C}_{29}\text{H}_{40}\text{O}_5$: C, 74.31; H, 8.62. Found: C, 74.39; H, 9.43 per cent.

4.1.14. *6-(4-Decyloxybenzoyloxy)naphth-2-yl 3-methylpentanoate (N-V)*

R_f 0.27 (50:50 hexane:dichloromethane). ^1H NMR (300 MHz, CDCl_3): δ 0.87 (t, $J = 7.0$ Hz, 3 H), 0.96 (t, $J = 7.5$ Hz, 3 H), 1.07 (d, $J = 6.8$ Hz, 3 H), 1.20–1.52 (m, 16 H), 1.79–1.83 (m, 2 H), 2.0–2.07 (m, $J = 6.2$ Hz, 1 H), 2.39 (dd, $J = 8.2$ Hz, $J = 8.2$ Hz, 1 H), 2.61 (dd, $J = 6.2$ Hz, $J = 6.0$ Hz, 1 H), 4.03 (t, $J = 6.6$ Hz, 2 H), 6.97 (d, $J = 9.0$ Hz, 2 H), 7.23 (dd, $J = 8.8$ Hz, $J = 2.4$ Hz, 1 H), 7.34 (dd, $J = 8.8$ Hz, $J = 2.4$ Hz, 1 H), 7.56 (d, $J = 2.2$ Hz, 1 H), 7.66 (d, $J = 2.4$ Hz, 1 H), 7.81 (d, $J = 8.8$ Hz, 1 H), 7.83 (d, $J = 9.0$ Hz, 1 H), 8.16 (d, $J = 9.0$ Hz, 2 H). IR (Nujol): 1754, 1730, 1608, 1513, 1270, 1212, 1170, 1144 cm^{-1} . Elemental analysis: calculated for $\text{C}_{33}\text{H}_{42}\text{O}_5$: C, 76.40; H, 8.18. Found: C, 76.58; H, 9.02 per cent.

4.1.15. *4-(4-Decyloxybenzoyloxyphenyl (2S,3S)-2-chloro-3-methylpentanoate (B-VI*)*

R_f 0.73 (80:20 hexane:dichloromethane). ^1H NMR (300 MHz, CDCl_3): δ 0.86 (t, $J = 6.6$ Hz, 3 H), 0.97 (t, $J = 7.3$ Hz, 3 H), 1.12 (d, $J = 6.6$ Hz, 2 H), 1.20–1.50 (m, 15 H), 1.71–1.84 (m, 3 H), 2.17–2.25 (m, 1 H), 4.02 (t, $J = 6.6$ Hz, 2 H), 4.37 (d, $J = 7.1$ Hz, 1 H), 6.95 (d, $J = 9.3$ Hz, 2 H), 7.15 (d, $J = 9.1$ Hz, 2 H), 7.22 (d, $J = 9.1$ Hz, 2 H), 8.11 (d, $J = 9.3$ Hz, 2 H). IR (Nujol): 1758, 1733, 1606, 1511, 1260, 1234, 1183, 1072 cm^{-1} . Elemental analysis: calculated for $\text{C}_{29}\text{H}_{39}\text{O}_5\text{Cl}$: C, 69.20; H, 7.8. Found: C, 69.34; H, 8.10 per cent.

4.1.16. *6-(4-Decyloxybenzoyloxy)naphth-2-yl (2S,3S)-2-chloro-3-methylpentanoate (N-VI*)*

R_f 0.35 (50:50 hexane:dichloromethane) ^1H NMR (300 MHz, CDCl_3): δ 0.89 (t, 3 H), 1.01 (t, $J = 8.0$ Hz, 3 H), 1.17 (d, $J = 6.8$ Hz, 3 H), 1.28–1.53 (m, 15 H),

1.80–1.85 (m, 3 H), 2.25 (m, 1 H), 4.06 (t, $J = 6.6$ Hz, 2 H), 4.42 (d, $J = 6.9$ Hz, 1 H), 6.98 (d, $J = 9.0$ Hz, 2 H), 7.26 (dd, $J = 9.0$ Hz, $J = 2.0$ Hz, 1 H), 7.38 (dd, $J = 8.8$ Hz, $J = 2.2$ Hz, 1 H), 7.61 (t, $J = 2$ Hz, 1 H), 7.68 (d, $J = 2.2$ Hz, 1 H), 7.85 (d, $J = 9$ Hz, 1 H), 7.86 (d, $J = 8.8$ Hz, 1 H), 8.17 (d, $J = 9.0$ Hz, 2 H). IR (Nujol): 1761, 1746, 1606, 1580, 1511, 1261, 1238, 1174, 1074 cm^{-1} . Elemental analysis: calculated for $\text{C}_{33}\text{H}_{41}\text{O}_5\text{Cl}$: C, 71.64; H, 7.48. Found: C, 71.30; H, 7.75 per cent.

4.1.17. *Determination of the optical purity*

In order to determine the optical purity of the non-racemic final products NMR spectroscopy was used.

Due to the diastereotopic nature of the protons of the chloro-ester tail, the presence of racemic forms can be easily detected. ^1H NMR spectra of compounds **B-VI*** and **N-VI*** showed only one doublet at δ 4.37 ppm and δ 4.42 ppm, respectively, corresponding to the α -proton [$-\text{OOC}-\underline{\text{CHCl}}-\text{CH}(\text{CH}_3)-\text{CH}_2\text{CH}_3$] of the chiral tail. Based on these results we concluded the presence of only one the isomer.

The *e.e.* determinations for the ether compounds (chiral tails **II*** and **III***) were performed using chiral shift reagents. The method developed was tested using racemic modifications of the products **B-II*** and **B-III*** which were prepared by similar synthetic methods to those reported for the non-racemic derivatives, but using racemic alcohols.

This method, previously reported by other authors for similar compounds [29, 30], involved the incremental addition to the tested compounds of the shift reagent tris-3-heptafluoropropylhydroxymethylene-(+)-camphorate) europium(III)[Eu(hfc)₃] until the desired resolution occurred.

The results obtained for **B-II*** and **B-III*** were as follows. For both compounds, a noticeable downfield shift was observed for protons *ortho*-to the carboxyl group of the core acid. These protons resonate at *c.* δ 8.09 ppm (**B-II***) and δ 8.11 ppm (**B-III***) and appear as doublets in the absence of the chiral shift reagent. For the (*R,S*)-**B-II***, the resonance of the protons is resolved into two doublets centred on δ 8.23 ppm and δ 8.20 ppm on addition of sufficient shift reagent. In the case of the racemic modification of **B-III*** two identical doublets at δ 8.38 ppm and δ 8.36 ppm were observed.

The optically active forms of (*R*)-**B-II*** and (*R*)-**B-III*** gave no resolution on addition of various amounts of [Eu(hfc)₃] and only showed downfield shifts. These results were attributed to the presence of essentially optically pure (*R*)-forms within the degree of error of the experiment.

Similar experiments were performed with (*R*)-**N-II*** and (*R*)-**N-III*** samples with identical results. We did not observe any resolutions of the resonance signals of the

ortho-protons by adding shift reagent—only downfield shifts. Based on these results and taking into account that the same synthetic method (Mitsunobu etherification) and the same starting alcohols were used to obtain either the phenyl (**B-II*** and **B-III***) or the naphthyl (**N-II*** and **N-III***) derivatives, we assumed that these four ether products were essentially optically pure.

4.2. Techniques

Microanalysis was performed using a Perkin–Elmer 240 B microanalyser. Infrared spectra were recorded using a Perkin–Elmer 1600 (series FTIR). Spectrometer in the 400–4000 cm^{-1} spectral range. All ^1H NMR spectra were recorded using a Varian Unity-300 operating at 300 MHz for ^1H .

The textures of the mesophases were studied with either a Nikon or an Olympus BH-2 polarizing microscope, equipped with a Mettler hot stage FP82 and control unit FP80 or a LINKAM hot stage THMS600 with a central processor TMS91 and a CS196 cooling system.

The purities of the final compounds were also satisfactorily checked by HPLC using a Waters 600E system with a photodiode detector 991.

Transition temperatures were determined by differential scanning calorimetry using a Perkin–Elmer DSC-7 calorimeter with a heating and cooling rate of 5°C min^{-1} . The apparatus was calibrated with indium at 5°C min^{-1} (156.6°C , 28.45 J g^{-1}).

Powder X-ray diffraction patterns were obtained using a Guinier diffractometer (Huber 644) operating with a $\text{CuK}\alpha_1$ beam from a germanium monochromator. The samples were held in rotating Lindemann glass capillaries ($\phi = 0.7 \text{ mm}$) and heated with a variable temperature attachment. The diffraction patterns were registered with a scintillation counter.

Polarization and tilt angle studies were carried out using commercial cells with ITO electrodes coated with polyamide. The triangular wave voltage was supplied by a Hewlett Packard 3245A function generator, and the current–voltage cycles were recorded by a digital acquisition system (*tech* ADC488/16A). All the equipment was interfaced to a microcomputer.

4.2.1. Experimental details of the ferroelectric measurements

The values of the spontaneous polarization (P_s) were determined by integrating the displacement current peak which appears due to the reversal of P_s in response to an applied triangular voltage [31]. The maximum amplitude, frequency and cell thickness were 40 Vpp, 50 Hz and $10 \mu\text{m}$ respectively. Good alignment was obtained by slow cooling (0.5 or 1°C min^{-1}) of the filled cell from the isotropic via the S_A phase.

Rotational viscosity γ_c was obtained from the parameters of the current peak calculated in the measurements of P_s . From both values we can calculate the response time using the equation $\tau = 1.75 \gamma_c P_s E$ [32].

The sign of P_s was determined by the field reversal method through optical observation of the extinction direction on rotating the stage according to Lagerwall's convention [33].

The tilt angles were measured as a function of temperature (sample between crossed polarizers), as half of the rotation angle between the two extinction positions associated with oppositely directed polarizations. The extinction positions were determined using a photomultiplier tube; the applied electrical d.c. field was of $5 \text{ V } \mu\text{m}^{-1}$.

This work was financed by the CICYT (projects MAT90-0813 and MAT91-0962-CO2-01) and the Ministerio de Educación y Ciencia of Spain (FPI grant to Y. González). We thank Dr J. Barberá (University of Zaragoza) for performing the X-ray diffraction experiments.

References

- [1] REINITZER, F., 1888, *Wien. Mh. Chem.*, **9**, 421.
- [2] WILLIAMS, R., 1967, U.S. Patent 3.322.485.
- [3] HARTMANN, W. J. A., 1991, *Ferroelectrics*, **122**, 355.
- [4] DEMUS, D., and ZASCHKE, H., 1974, *Flussige Kristalle in Tabellen I* (VEB). DEMUS, D., and ZASCHKE, H., 1984, *Flussige Kristalle in Tabellen II* (VEB).
- [5] LAUK, U., SKRABAL, P., and ZOLLINGER, H., 1981, *Helv. chim. Acta*, **64**, 1847.
- [6] COATES, D., 1987, *Molec. Crystals liq. Crystals.*, **41**, 119.
- [7] WEDLER, W., DEMUS, D., ZASCHKE, H., MOHR, K., SCHAFER, K. W., and WEISSFLOG, W., 1991, *J. mater. Chem.*, **1**, 347.
- [8] MOCHIZUKI, A., MOTOYOSHI, K., and NAKATSUKA, M., 1991, *Ferroelectrics*, **122**, 37.
- [9] SIERRA, T., SERRANO, J. L., ROS, M. B., EZCURRA, A., and ZUBÍA, J., 1992, *J. Am. chem. Soc.*, **114**, 7645.
- [10] MARCOS, M., OMENAT, A., SERRANO, J. L., SIERRA, T., and EZCURRA, A., 1992, *Adv. Mater.*, **4**, 285.
- [11] HIRD, M., TOYNE, K. J., and GRAY, G. W., 1993, *Liq. Crystals*, **14**, 741.
- [12] HIRD, M., TOYNE, K. J., GRAY, G. W., DAY, S. E., and McDONNELL, D. G., 1993, *Liq. Crystals*, **15**, 123.
- [13] CALUNDANN, G., JAFFE, M., JONES, R. S., and YOON, H., 1988, *Fibre Reinforcements for Composite Materials*, edited by A. R. Bunsell (Amsterdam), p. 211.
- [14] WIEGAND, C., 1954, *Z. Naturf. (b)*, **9**, 516.
- [15] GONZÁLEZ, Y., ROS, M. B., and SERRANO, J. L., 1994, *Chem. Mater.*, **6**, 1516.
- [16] TWIEG, R. T., BETTERTON, K., HINSBERG, W., WONG, P., TANG, W., and NGUYEN, H. T., 1991, *Ferroelectrics*, **114**, 295.
- [17] GOODBY, G. W., 1991, *Ferroelectric Liquid Crystals: Principles, Properties and Applications*, edited by G. W. Taylor (Gordon & Breach Science Publishers), Chap. 2.
- [18] DEMUS, D., and RICHTER, L., 1978, *Textures in Liquid Crystals* (Verlag Chemie). GRAY, G. W., and GOODBY, J. W., 1984, *Smectic Liquid Crystals* (Leonard Hill).

- [19] KELLER, P., CLADIS, P. E., FINN, P. L., and BRAND, H. R., 1985, *J. Phys., Paris*, **46**, 2203.
- [20] DEMUS, D., and ZASCHKE, H., 1974, *Flussige Kristalle in Tabellen I* (VEB), p. 69.
- [21] HALLER, I., and COX, R. J., 1970, *Liquid Crystals and Ordered Fluids* Vol. 1, edited by J. F. Johnson and R. S. Porter (Plenum Press, New York), p. 393.
- [22] CANO, M., GONZÁLEZ, Y., IGLESIAS, Y., ROS, M. B., and SERRANO, J. L., 1994, *15th International Liquid Crystal Conference, Hungary*. IGLESIAS, R., SERRANO, J. L., and SIERRA, T. (submitted for publication).
- [23] WALBA, D., RAZAVI, H. R., HORIUCHI, A., EIDMAN, K. F., OTTERHOLM, B., CURTIS, HALTINANGER, R., CLARK, N. A., SHAD, R., PARMAR, D. S., WAND, M. D., and VOHRA, R. T., 1991, *Ferroelectrics*, **113**, 21.
- [24] ESCHER, C., GEELHAAR, T., and BOHM, E., 1988, *Liq. Crystals*, **3**, 469.
- [25] FUJISAWA, K., SEKINE, C., UEMURA, Y., HIGASHI, T., MINAI, M., and DOHGANE, T., 1991, *Ferroelectrics*, **121**, 167.
- [26] LAGERWALL, S. T., OTTERHOLM, B., and SKARP, K., 1987, *Molec. Crystals liq. Crystals*, **152**, 503.
- [27] MARTINOT-LAGARDE, P. H., DUKE, R., and DURAND, G., 1986, *Molec. Crystals liq. Crystals*, **75**, 249.
- [28] GOODBY, J. W., 1991, *J. mater. Chem*, **1**, 307.
- [29] BOOTH, C. J., GRAY, G. W., TOYNE, K. J., and HARDY, J., 1992, *Molec. Crystals liq. Crystals*, **31**, 210.
- [30] BOOTH, C. J., GOODBY, J. W., HARDY, P. J., LETTINGTON, O. C., and TOYNE, K. J., 1993, *J. mater. Chem.*, **3**, 821.
- [31] DE LA FUENTE, M. R., EZCURRA, A., PÉREZ-JUBINDO, M. A., and ZUBÍA, J., 1990, *Liq. Crystals*, **7**, 51.
- [32] KIMURA, S., NISHIYAMA, S., OUCHI, Y., TAKEZOE, H., and FUKUDA, A., 1987, *Jap. J. appl. Phys.*, **26**, L255.
- [33] LAGERWALL, S. T., and DAHL, I., 1984, *Molec. Crystals liq. Crystals.*, **114**, 151.
- [34] TINH, N. H., SALLENEUVE, C., BABEUN, A., GALVAN, J. M., and DESTRADE, C., 1987, *Molec. Crystals liq. Crystals*, **151**, 147.